

Hornet 565

Parallel robot ideal for use in the food and beverage, pharmaceutical, and healthcare industries



- Programmable through ACE software and eV+ language, or through the familiar IEC 61131-3 when using ePLC Connect
- The amplifier and controller built into the robot reduces the number of cables
- Tracks up to a conveyor speed of 1.4 m/s
- Designed with a high payload to support multi-hand (multi-picking)
- Supports fast Pick & Place on a fast conveyor
- Helps reduce mounting cost and robot vibration
- Maximum working diameter 1,130 mm
- Working height 425 mm
- Maximum payload 8 kg
- Weight 52 kg

Specifications

Product name		Hornet			
Size		565			
Number of axes		3 Axis		4 Axis	
IP		Standard	IP65/67	Standard	IP65/67
Part Number		1720[]-45600	1720[]-45610	1720[]-45604	1720[]-45614
Mounting		inverted			
Working volume	X,Y axis (stroke)	1130 mm			
	Z axis (stroke)	425 mm			
	theta axis (rotation angle)	-		±360°	
Maximum Payload		8 kg		3 kg	
Repeatability		±0.10 mm			
Cycle times, sustained, 20°C ambient *1	Payload 0.1 kg	0.32 s		0.35 s	
	Payload 1.0 kg	0.34 s		0.37 s	
	Payload 3.0 kg	0.38 s		0.42 s	
Power Requirements		24 VDC: 6 A 200 to 240 VAC: 10 A, single-phase			
Protection	Base	IP20	IP65	IP20	IP65
	Topside of robot	IP65			
	Underside of robot	IP65			
Platform, Arms		IP67			
Environment Requirements	Ambient Temperature	1 to 40°C			
	Humidity Range	5 to 90% (non-condensing)			
Weight		52 kg			
Basic configuration	Controller	eAIB			
	On-board I/O (Input/Output)	12/8			
	Conveyor tracking input	2			
	RS-232C serial communications port	1			
	Programming environment	ACE, ePLC			
	ACE Sight	Yes			
	ePLC Connect	Yes			
ePLC I/O	Yes				
Connectable controller *2		SmartController EX, NJ/NX/NY Series *3			

*1. Adept cycle, in mm (25/305/25)

*2. Choose a controller to suit your application.

*3. The robot version 2.3.C or later is required to connect with the NJ/NX/NY Series.

Dimensions

(Unit: mm)

Hornet 565

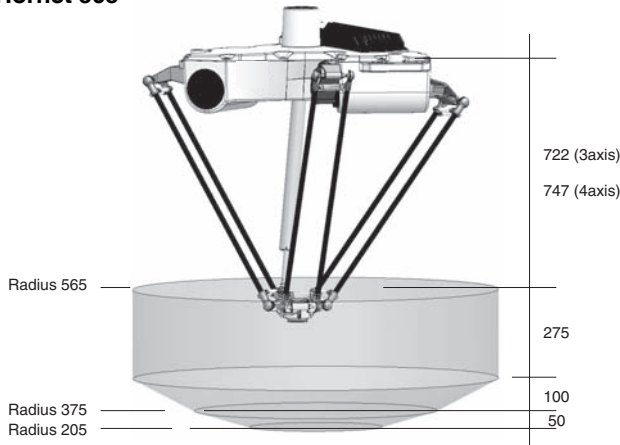

Flange

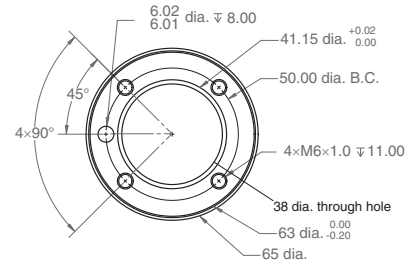

Front panel



Footprint

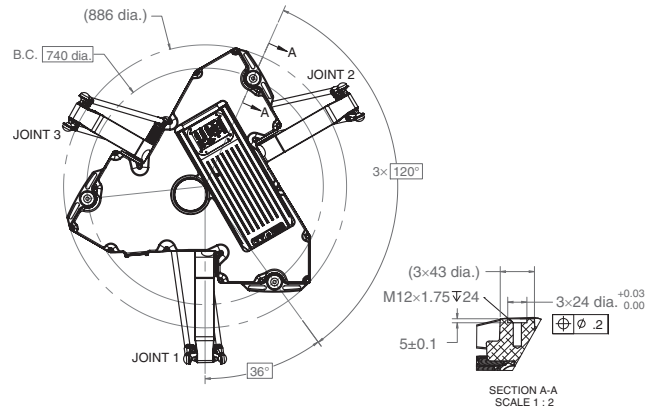

Robot Parts Code and Bundled Accessories

Type	Hornet		Hornet Add-On	
	Standard	IP65/67	Standard	IP65/67
Hornet 565 3 Axis	17201-45600	17201-45610	17203-45600	17203-45610
Hornet 565 4 Axis	17201-45604	17201-45614	17203-45604	17203-45614
Overview	Robot + eAIB with fully integrated controller		Robot + eAIB required connection cables	
Purpose	Typical for use in single robot system		Typically added to systems with an existing SmartController EX to create multi-robot systems	
Bundled Accessories	<ul style="list-style-type: none"> XSYSTEM cable with jumpers, 1.8 m/6 ft (13323-000) Front panel kit (92546-10358) 	<ul style="list-style-type: none"> XSYSTEM cable with jumpers, 1.8 m/6 ft (13323-000) Front panel kit (92546-10358) Cable Seal Kit (08765-000) 	<ul style="list-style-type: none"> XSYSTEM cable with jumpers, 1.8 m/6 ft (13323-000) XSYS cable, 4.5 m/15 ft (11585-000) DB9 splitter (00411-000) 1394 latch cable, 4.5 m/15 ft (13632-045) eV+ license to connect to controller (14529-103) 	<ul style="list-style-type: none"> XSYSTEM cable with jumpers, 1.8 m/6 ft (13323-000) XSYS cable, 4.5 m/15 ft (11585-000) DB9 splitter (00411-000) 1394 latch cable, 4.5 m/15 ft (13632-045) eV+ license to connect to controller (14529-103) Cable Seal Kit (08765-000)